



# *Technical guide*

## **Folder** **0** - **1510**

---

### **Description and performances**

---

The quartz watch, Megaquartz 2400 is the first watch whose oscillator is equipped with a high frequency quartz (2.4 million oscillations per second = 2.4 MHz).

This ensures great accuracy - less than one second variation per month. The watch is fitted with a calendar, a pusher for correcting the second, as well as a rapid hour corrector which enables it to be adapted to the time zone without loss of accuracy in minute and second.

## 1. The HF resonator

The high frequency (HF) quartz gives better results than other types of quartz in all respects: shock resistance, low temperature coefficient, slow ageing.

Both surfaces of the lenticular shaped crystal are metallized so as to permit electric maintenance.

Vibration is of the shearing type: the upper part of the crystal moves in the opposite direction to the lower part. Thus, there is no vibration in the neutral surface and the quartz can therefore be fixed securely with the certainty of great resistance to shocks.

The influence of temperature on performance is shown by a graphic curve whose inflexion point is in the neighbourhood of  $28^{\circ}\text{C}$ . One may concede that it is a straight line between  $+10^{\circ}$  and  $+50^{\circ}\text{C}$ . By judicious cutting of the crystal, the inclination of this straight line may be altered in order to obtain a thermic coefficient approaching 0 around  $28^{\circ}\text{C}$ . The watch will be adjusted to a zero rating at the average temperature of wear ( $28^{\circ}\text{C}$ ). Any variation around this temperature will thus incur a slight loss or gain.

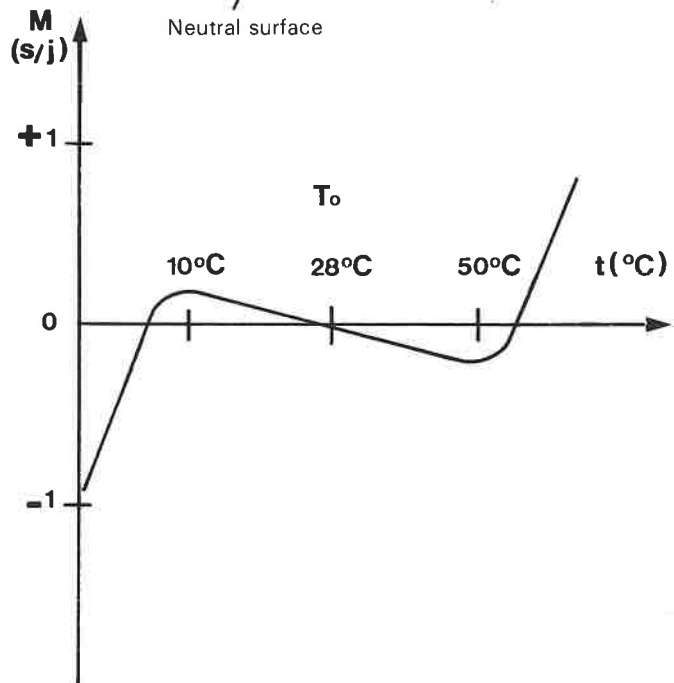
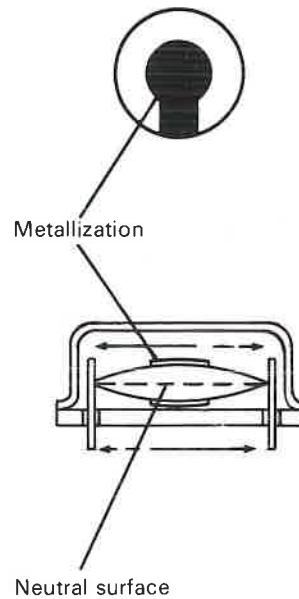

## 2. Working principle

The quartz resonator (1) is maintained at its sound frequency (2'359'296 Hz) by the oscillator maintenance circuit (2).

The trimmer (3) permits adjustment of the quartz within approximate limits of  $\pm 2$  secs. per day. This frequency of approximately 2.4 MHz is then divided by 6 by the analogical divider (4) which comprises a transformer (5), namely to 393'216 Hz.

18 logical division stages (6) (17 dividers by 2 and 1 divider by 3) lower the frequency to 1 Hz. The energy is supplied by the power cell (10).

After setting-up, the control circuit (7) feeds the motor (8) each second with an impulse lasting 6 ms. The motor, of the electro-dynamic type, converts the electrical data into mechanical data for the time display module (9).

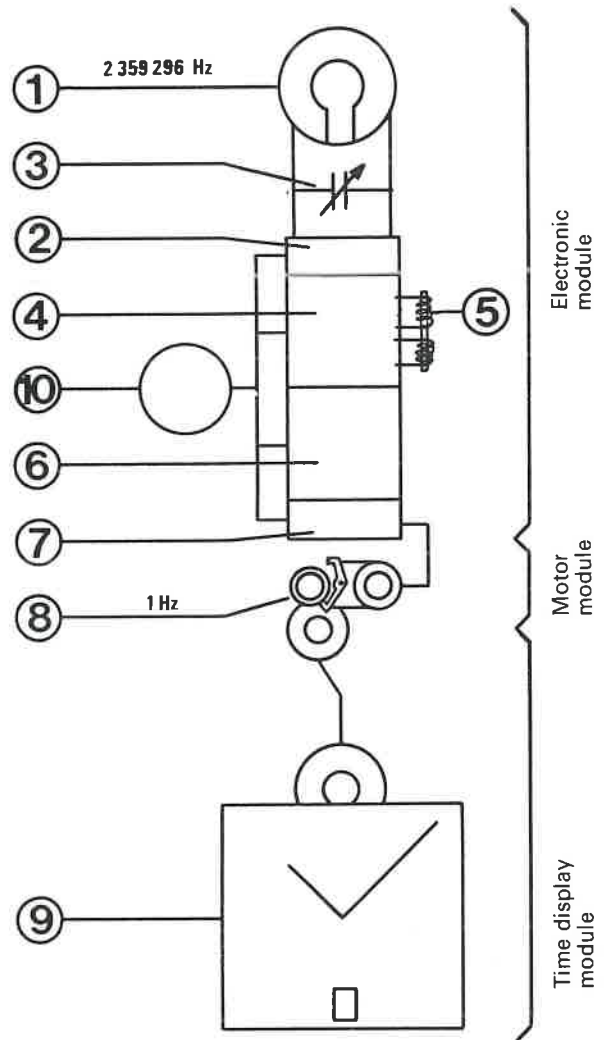

## 3. Description of movement

The watch consists of 3 modules:

1. The electronic module comprising the quartz resonator with its trimmer, the integrated circuit, the transformer, the connecting point with the motor, the phasing contacts for the second and for correction of the second.

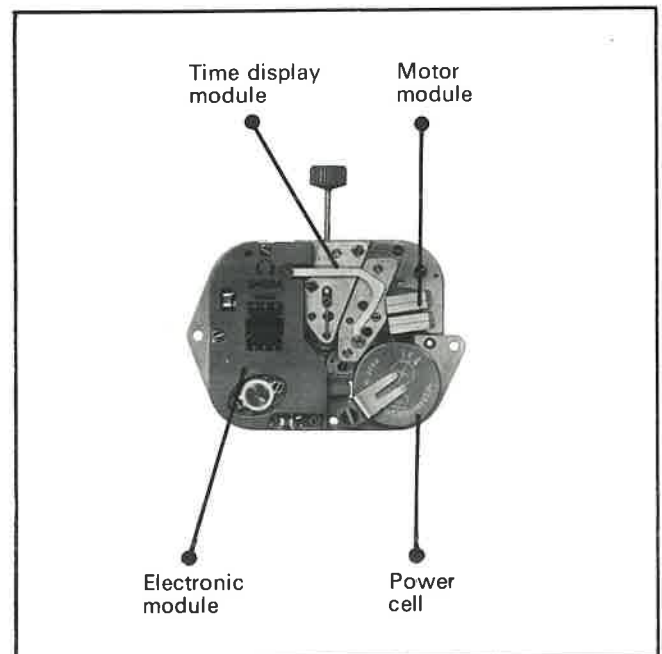

2. The motor module comprising the mobile equipment with its coil, its hair-springs and pallet fork; the magnetic circuit consisting of 2 pairs of magnets and lastly the motor wheel.
3. The time display module comprising the reduction wheel-train, the date and the hour corrector.

### Electronic module

The miniature printed circuit (6) forms the support of the module. It is fixed to the plate by 3 screws (2) one of which ensures electrical contact on the plate.

The module consists of the following:

- the quartz (3) and trimmer (4) constituting the time basis
- the transformer (5) serving for a first analogical division
- the integrated circuit (1) which comprises:
  - the quartz maintenance circuit EQ
  - one analogical division stage using the transformer (5) DA
  - one logical division stage DL
  - the circuit forming the appropriate impulse for the motor CM
- two capacities (7)
- the power cell contact blade (8) ensuring feed of module

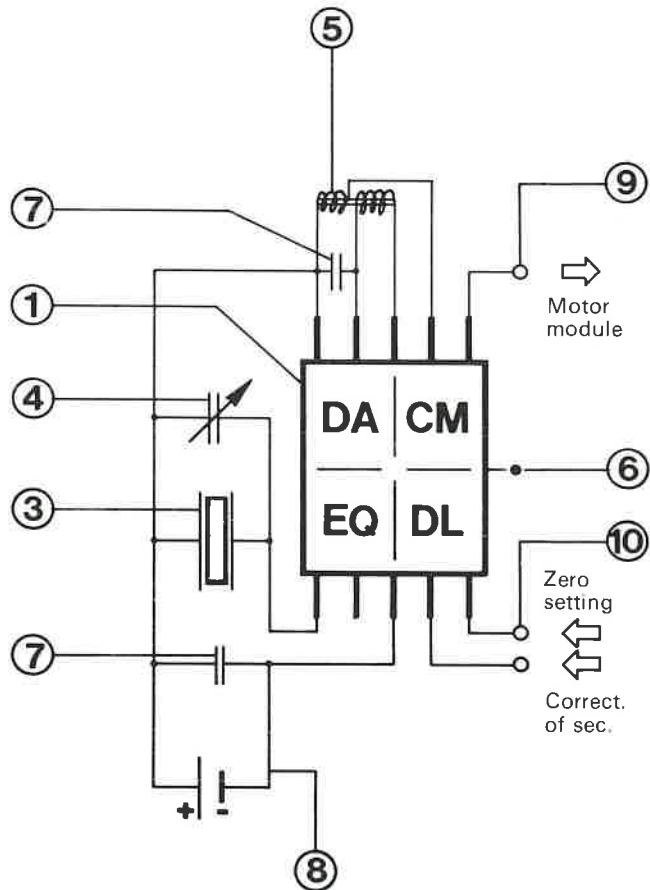

- the motor contact stud (9), connecting point with motor module
- the stud for resetting to zero (10). When the hour is corrected, it sets the divider back to zero (position 3 of hand-setting stem). Exact phasing of the second with the time signal is thus ensured.
- the second contact blade (11) operated by a pusher. Each time the latter is pressed, a correcting impulse is conveyed to the motor.

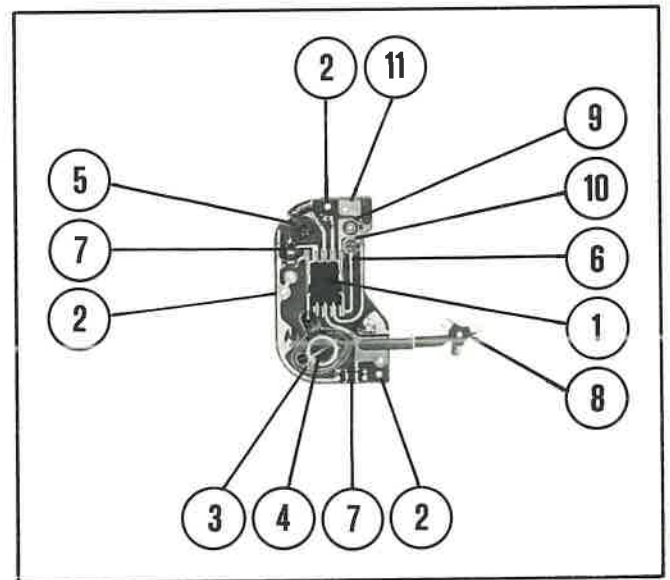

### Motor module

The motor, of the electro-dynamic step-by-step type, receives each second from the electronic module an impulse lasting 6 ms.

The mobile part of the motor carries a motive coil (1), a pallet fork (2) which controls and checks the motor wheel (5) by means of 2 pallets (3) (4). The two hair-springs (6) ensure external connection of the coil as well as the return of the mobile equipment to resting position.

During the resting stage, the mobile organ is held in place by the return force of the hair-springs; in this position the pallet (4) locks the motor wheel.

At the time of the electric impulse, the coil with a current running through it produces a magnetic field which, interacting with the permanent magnetic field of the 2 pairs of magnets (7), is transformed into a mechanical couple, thus in motion by percussion of the pallet (3) on the motor wheel (5).

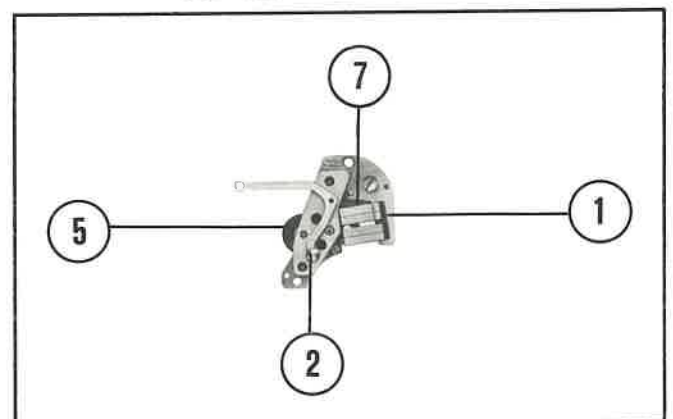
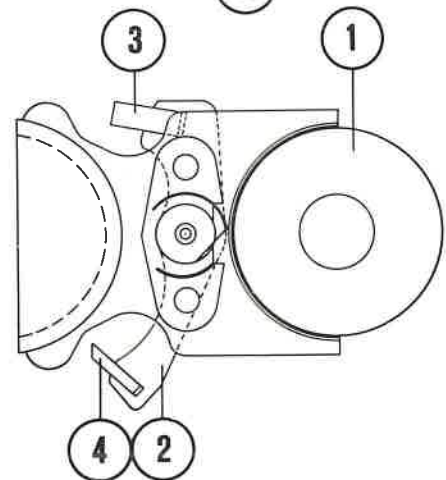
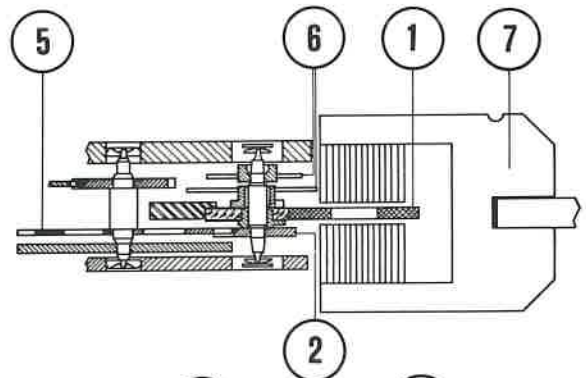

## Time display module

This module comprises on one side the second wheel (1), the third wheel (2) and a brake-spring (3) acting in conjunction with the second wheel staff. The stop-second lever (4) is fixed on the plate. It is controlled by the stem (5) and acts upon the zero setting stud of the electronic unit. The power cell is held on the time display module by the clamp (6).

On the other side of the module one finds the date mechanism and hour corrector mechanism.

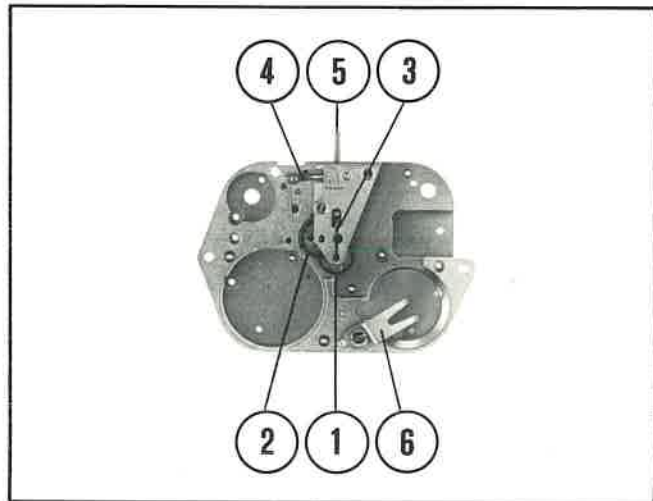

## Date

The two date setting wheels (7-8) control the driving wheel (9) which makes one revolution in 24 hours. The latter is provided with a finger (10) which sets in motion the driver (11) bearing four pins of which two, the longest, drive the date disc (12).

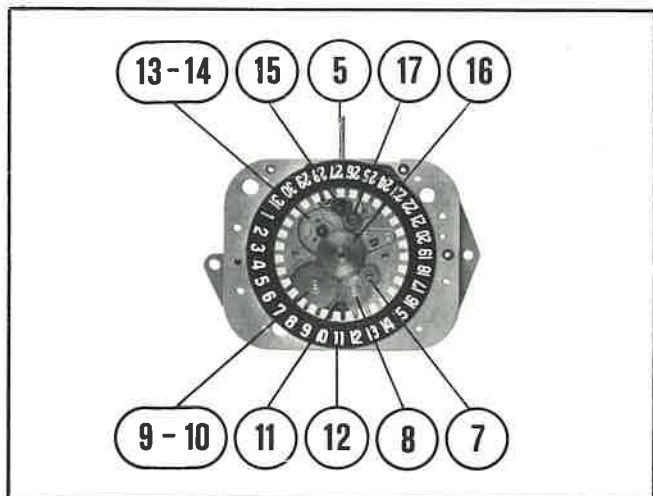

## Hour corrector

The dial-train (13-14) consists of two superimposed wheels, coupled magnetically by the magnets (19). In position 1 of the stem, it operates as one dial-train only. In position 2 of the stem, one plate only (13) of the dial-train is driven by the setting wheel (15), which enables the hour wheel (16) to be displaced without interfering with the wheel train. In position 3 of the stem, a pinion (17) penetrates into the dial-train and binds the two superimposed wheels interdependently. Hand-setting is then carried out in the conventional manner, cannon-pin friction being created by the flexible arms of the center wheel (18).

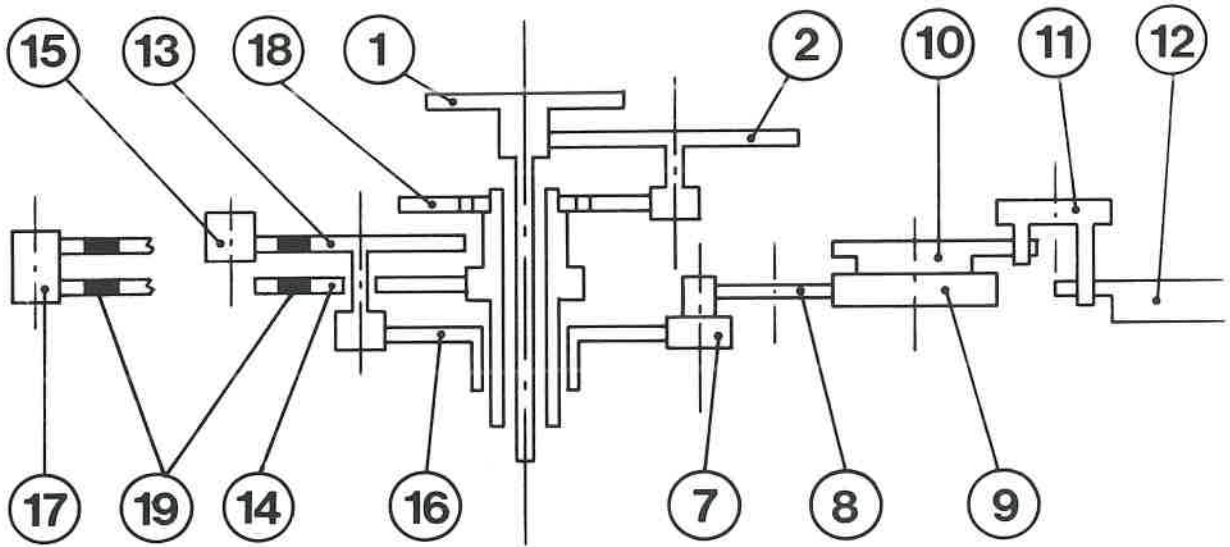

Hour and Date correctors

Setting to the hour and the second

These operations are carried out by means of the 3 position stem and pusher (4).

Stem

Position 1: Neutral

Position 2: Correction of hour and date by means of the hour corrector

Position 3: Stop second - hour setting, phasing of the second hand

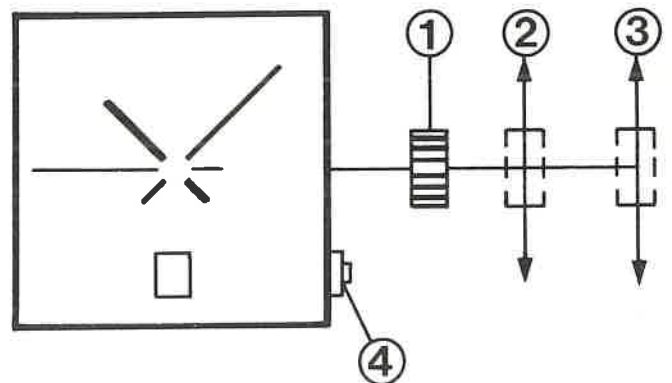

Pusher (4)

Each time the pusher is pressed, a second is added.

4. Technical data and performance  
of caliber 1510

---

Dimensions : 31x25.60x6 mm

Frequency of  
resonator : 2.359.296 Hz

Quality  
factor : > 250.000

Thermic  
coefficient : < 0.025 s/d/°C  
(between  
0° and +60°C)

Isochronism : < 0.04 s/d/100 mV

Consumption : max. 13  $\mu$ A

Running time: 15 months

Variations  
during wear : < 1 sec;/month



# Technical guide

## Folder **1-1510**

### Replacement of the power cell

#### IMPORTANT

To be observed strictly

Do not uncase the movement. Only persons with the necessary training and equipment can carry out this operation.

The watch must in no case be demagnetized.

In order not to disturb the proper functioning of the watch, the electronic module (fig. 1.1) must not be touched with any tool, nor with the fingers.

Handle the new power cell with tweezers having insulated tips (fig. 2.1).

#### EQUIPMENT

Insulated tweezers

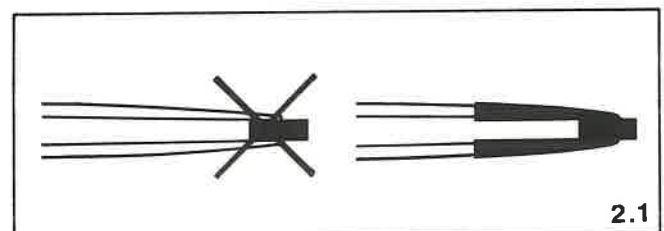
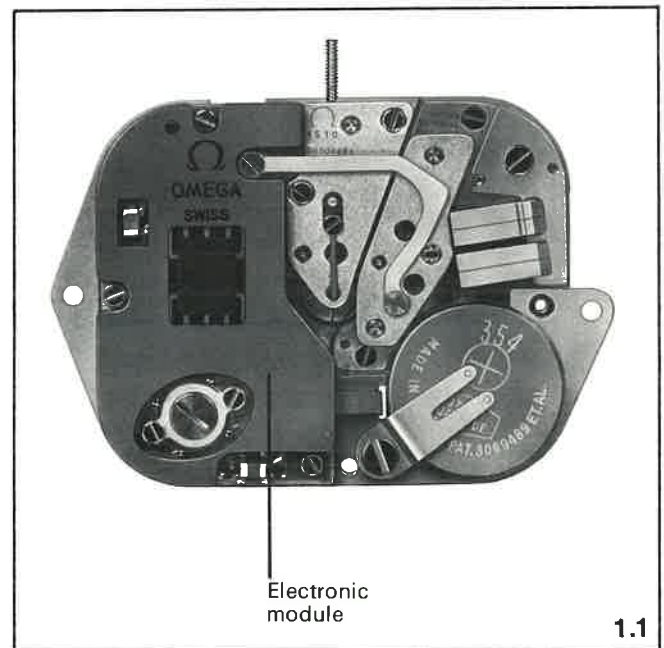

## REPLACEMENT OF THE POWER CELL

- 1.1 Open the case.
- 1.2 Remove and clean the back.
- 1.3 Remove the power cell bridge No. 1510.9200 by unscrewing the respective screw.
- 1.4 Remove by suction any possible burrs caused by the screw of the power cell bridge.
- 1.5 Remove the faulty power cell by turning over the watch.
- 1.6 Check cleanliness of the two power cell contacts. If necessary clean them. Should the contacts be oxidized, then it is essential in the case of :

- the power cell bridge (positive pole) : to replace the bridge No. 1510.9200.
- the lower power cell contact (negative pole) : to clean the bridge very carefully with a buff.

If the power cell has leaked inside its seating, the watch should be returned to the agent.

- 1.7 Check the new power cell and even if there is only a minute leakage, do not use it. Place the new power cell No. 9903 in position, positive pole (+) uppermost (fig. 3.1).
- 1.8 Refit the power cell bridge and screw thoroughly.
- 1.9 Grease the water-resistance gasket. Close the case.

- 1.10 When screwing the back of shaped cases after replacement of the power cell, tighten the 4 screws successively in the order 1-2-3-4 (fig. 4.1).
- 1.11 Check waterproofness of the watch.

## COMPONENTS

No. 1510.9200	Power cell bridge (screw fitted)
No. 9903	Power cell, tension 1.35 V.

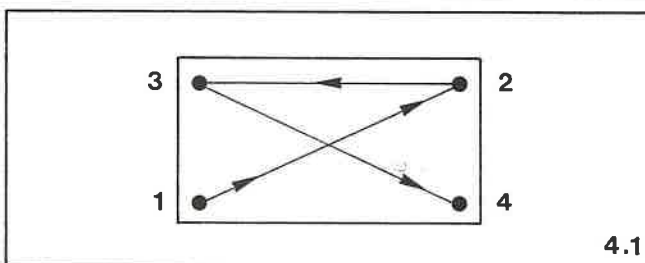
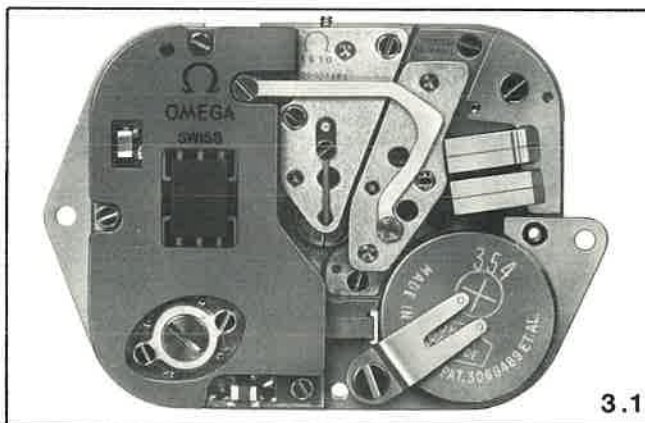



# Technical guide

## Folder **2-1510**

### Adjustment of the rate

#### IMPORTANT

To be observed strictly

Do not uncase the movement.  
Only persons with the necessary training and equipment can carry out this operation.

The watch must in no case be demagnetized.

In order not to disturb the proper functioning of the watch, the electronic module (fig. 1.2) must not be touched with any tool excepting the key for trimmer, nor with the fingers.

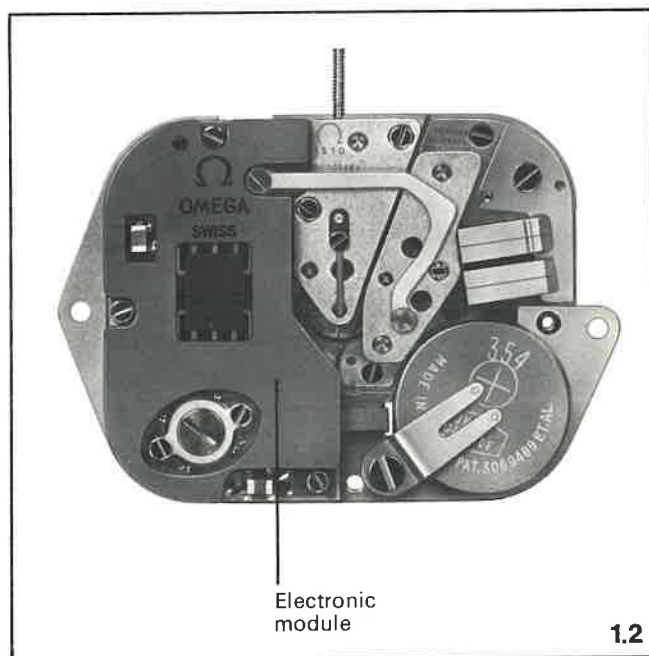

#### EQUIPMENT

Key for trimmer

- The indications given refer to Deltatest ODT 3 and Alitest OAT 2.

- Indications within brackets [ ] refer to Deltatest ODT 1 and Alitest OAT 1.
- All apparatus where model is not indicated on the rear plate correspond to ODT 1 and OAT 1.

## ADJUSTMENT OF THE RATE

- 2.1 Open the case.
- 2.2 Remove and clean the back.
- 2.3 Place watch on the captor, movement side up and press button " $\leq 15$  Hz" ["1 Hz"] of Deltatest.

### Note

- As a general rule, a measuring time of 12 [10] seconds and a measuring accuracy of .99 [1/100th] second would be used.
  - In order that the temperature of the watch may be equal to the ambient temperature, it is necessary to wait one hour before the measuring is effected.
- 2.4 Read the instant rate shown on the Deltatest.

### Note

- Adjustment can only be effected if the daily rate is lower than the possibilities offered by the trimmer. Correction limit : 3 sec.
  - If the daily rate is higher than the correction limits possible, the watch must be returned to the agent.
- 2.5 In the case where correction of the daily rate is possible, adjust this rate by means of the trimmer, using the key specially devised for this purpose (fig. 2.2.). This key must be used so as not to damage the trimmer. Avoid excessive pressure during this operation.

- 2.6 Adjustment of the watch during wear within  $\pm 3$  seconds per month for an ambient temperature of  $22^{\circ}\text{C}$  -  $25^{\circ}\text{C}$  (fig. 3.2.).

- Turn the rotor of the trimmer in the required direction until the rate is  $+ 0.04$  sec.
- When the watch is being worn, its temperature is around  $28^{\circ}\text{C}$ . In order to adjust the watch within  $\pm 1$  sec/month, proceed in the following manner :

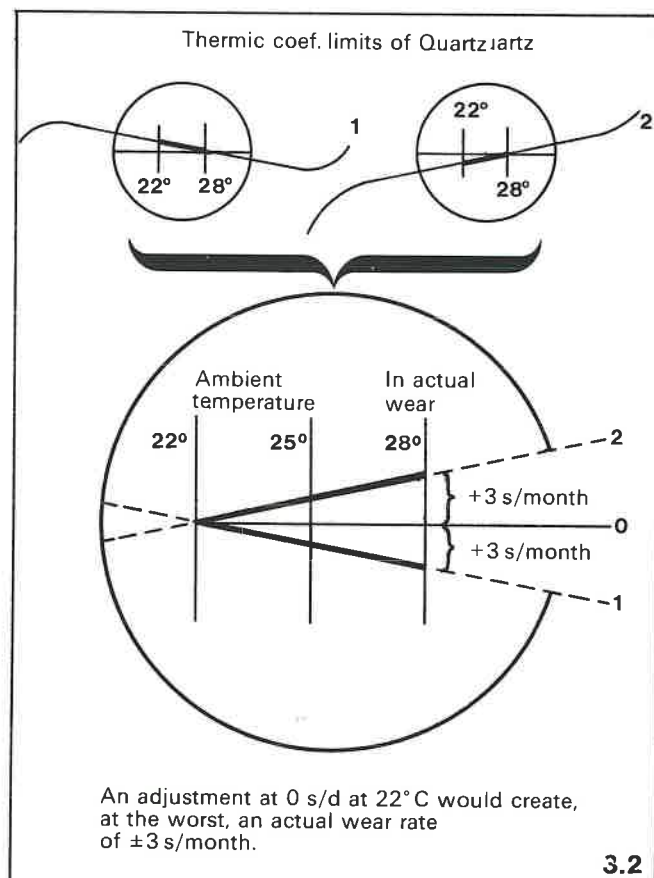
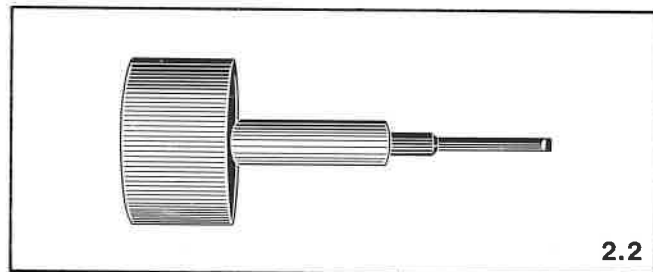

- Note the rate (M) of the watch after 30 days, using an absolutely reliable check.
- Calculate the average daily rate (m) by dividing  $M/30 = m$  in s/d.
- Note the rate ( $m_D$ ) taken on Deltatest.
- The value of the new rate ( $m_n$ ) will be the difference between the average rate (m) and the instant rate on Deltatest ( $m_D$ ).
- Adjust the trimmer until this calculated value appears on the Deltatest.

#### 2.7 Example No. 1

The watch is gaining 3 seconds in 1 month :

$$m_D = + 0.05 \text{ s/d}$$

$$m = \frac{+3\text{s}}{30} = + 0.10 \text{ s/d}$$

$$m_n = m_D - m = +0.05 - 0.10 \\ = - 0.05 \text{ s/d}$$

#### Example No. 2

The watch is losing 3 seconds in 1 month :

$$m = \frac{- 3 \text{ s}}{30} = - 0.10 \text{ s/d}$$

$$m_n = m_D - m = + 0.05 - (-0.10) \\ = + 0.15 \text{ s/d}$$

- 2.8 Grease the water-resistance gasket. Close the case.
- 2.9 Check waterproofness of the watch.





# Technical guide

## Folder **3-1510**

### Standard exchange of the movement or modules

#### IMPORTANT

To be observed strictly

The watch must in no case be demagnetized.

Handling of the power cell should be effected by means of tweezers with insulated tips.

DO NOT touch the electronic module with the fingers.

The motor module must IN NO CASE be disassembled.

DO NOT clean the electronic module and the motor module in baths.

The wheel-train must IN NO CASE be turned manually in one direction or the other when the motor is in position.

For all operations pertaining to uncasing, casing-up or manipulation of hands, NEVER make the second hand turn if the motor is fitted on the movement.

The use of non-magnetic tweezers is recommended for all operations.

#### EQUIPMENT

##### - Movement holder 1510

This is used for assembling of the movement. The latter may be placed in both positions, i.e. dial up or down (fig. 1.3.)

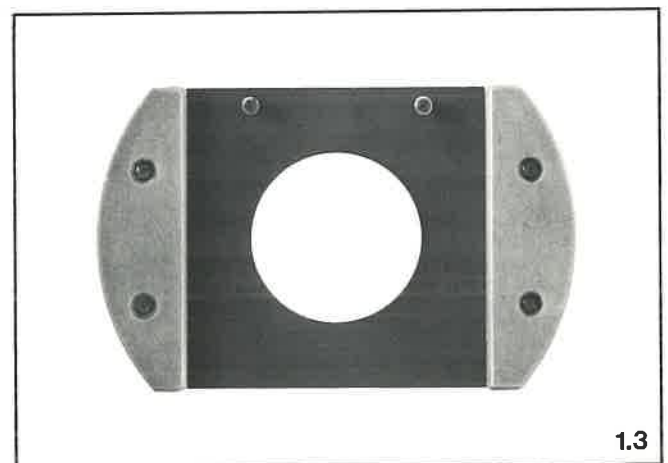

- Key for trimmer 1510

The above key is used when adjusting the rate of the watch by means of the trimmer (fig. 2.3.)

- Feed by substitute power cell

With this accessory consumption of the electronic module alone or that of the complete movement may be checked (fig. 3.3.).

- Deltatest measuring apparatus

The above enables the exact instant rate of the watch to be ascertained (see folder 5-6 - 1510).

- Alitest control apparatus

This permits a fixed or variable feed to be supplied, as well as enabling all necessary tests to be effected for diagnostic purposes (see folder 5-6 - 1510).

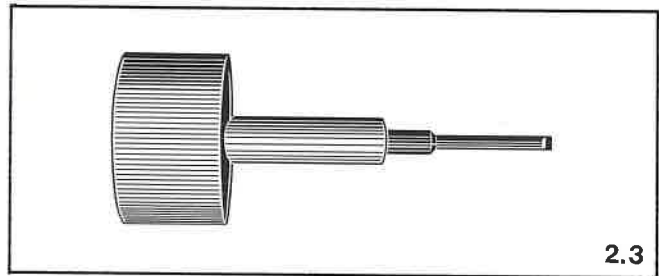

ensure that the setting lever stud enters into the groove of the stem.

## EXCHANGE OF THE MOVEMENT

- 3.1. Open the case.
- 3.2. Remove and clean the back.
- 3.3. Remove the power cell bridle No. 1510-9200 by unscrewing its screw and extract the power cell No. 9903.
- 3.4. Remove the hand-setting stem No. 1510-9050 by pressing the settling lever staff.
- 3.5. Unscrew and remove the two fixing screws of the movement No 2393.
- 3.6. Extract the movement by carefully turning over the watch and place the former on movement holder 1510.
- 3.7. Refit the hand-setting stem, pushing it in completely to
- 3.8. Remove simultaneously the three hands, and take off the dial. Remove the faulty movement from the movement holder.
- 3.9. Place the new movement on the movement holder and pull the hand-setting stem into position III (hand setting).
- 3.10. Fit the dial and hands.
- 3.11. Check that the date change occurs when the hands are at midnight.
- 3.12. Extract the movement from the movement holder and remove the hand-setting stem by pressing the setting lever staff.
- 3.13. Insert the movement in the case.
- 3.14. Grease the water-resistance gasket for the crown. Place hand-setting stem in position.

- 3.15. Screw the two fixing-screws of the movement.
- 3.16. Feed the watch by means of the substitute power cell. Fix the latter using the power cell bridle No 1510-9200.
- 3.17. Measure and record the total consumption of the movement, tension 1.35 V (see application Alitest, folder 5-6 - 1510). Consumption must not exceed  $14\mu\text{A}$ .

#### Note

If the consumption measured during operation 3.17. exceeds the prescribed limits, please refer to Diagnostic.

- 3.18. Remove the substitute power cell.
- 3.19. Place power cell and power cell bridle in position. Screw tightly (see folder 1-1510).
- 3.20. Proceed with adjustment of the rate (see folder 2-1510)
- 3.21. Grease the water-resistance gasket and close the case.
- 3.22. Check the rate during a few days.
- 3.23. Check adjustment again by Deltatest and correct rate if necessary.

#### EXCHANGE OF ELECTRONIC MODULE

---

- 3.24. After having removed the back of the case and the power cell, unscrew and withdraw the motor contact screw No 2594, point (1) (fig. 4.3.).

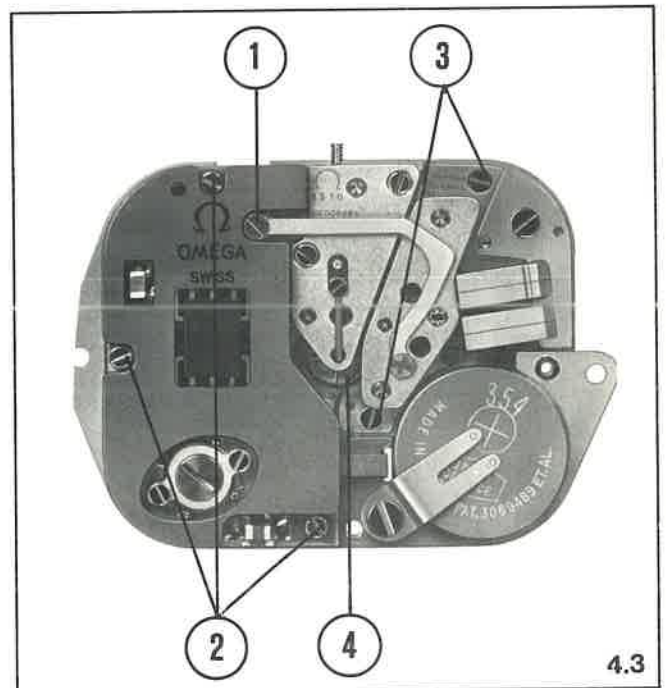

- 3.25. Remove the three screws of the electronic module No 2399 as well as the three contact washers No 1510-9151 located under the head-screws.
- 3.26. Place the new electronic module in position. Fix the latter by means of the three screws, bearing in mind to fit one contact washer under each head-screw.
- 3.27. Fit and tighten the motor contact screw.
- 3.28. Place the power cell bridle in position, tighten the screw completely (see folder 1-1510).
- 3.29. Proceed with adjustment of the rate (see folder 2-1510)
- 3.30. Grease the water-resistance gasket and close the case.
- 3.31. Check the rate during a few days.
- 3.32. Check adjustment again by Deltatest and correct the rate if necessary.

## EXCHANGE OF MOTOR MODULE

---

- 3.33. After having removed the back of the case and the power cell, unscrew and withdraw the motor contact screw No 2594, point (1) (fig. 4.3.).
- 3.34. Remove the faulty motor module No 1510.9100 by unscrewing its two screws No 2397 (3).
- 3.35. Important  
Place the new motor module in position, taking care to ensure that the motor pinion does not damage the teeth of the center second wheel No 1510.9015 (4). Hold the motor module in place by means of a skin-covered buff, screw and lock the two fixing screws of the motor module.
- 3.36. Fit and tighten the motor contact screw.
- 3.37. Check the rate by Deltatest. If necessary, proceed with adjustment of the rate as per order of operations 3.20 to 3.23.



# *Technical guide*

**Folder** **4-1510**

---

**Diagnostic  
Disassembling  
Cleaning  
Reassembling and  
lubrification of  
movement**

---

IMPORTANT - To be observed strictly

- The watch must in no case be demagnetized.
- Handle the power cell with tweezers having insulated tips.
- DO NOT touch the electronic module with the fingers.
- The motor module must IN NO CASE be disassembled.
- DO NOT clean the date indicator, power cell, motor module, electronic module and minute wheel in baths (see Cleaning, page 4-1510/3).
- For all operations involving uncasing, casing-up or manipulation of hands, NEVER make the second hand turn if the motor module is fitted on the movement.
- The use of non-magnetic tweezers is recommended for all operations.

## EQUIPMENT

### - Movement holder 1510

This is used for assembling of the movement. The latter may be placed in both positions, i.e., time display on top or underneath (fig. 1.4).

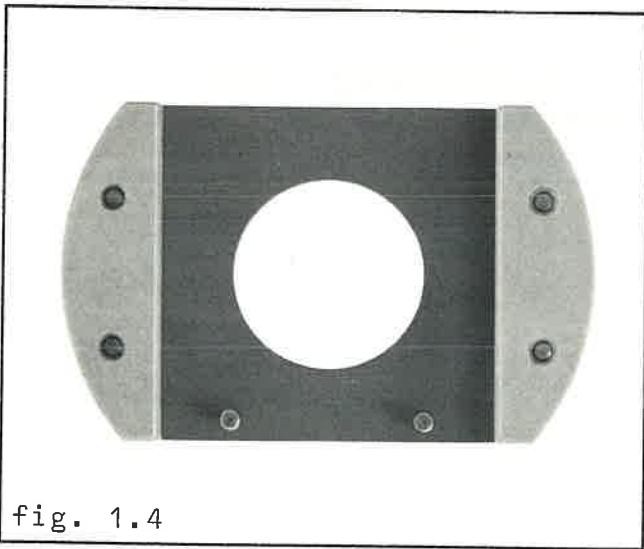

### - Feed by substitute power cell 1510

This accessory makes it possible to check consumption of the electronic module alone, or of the complete movement. It also enables the movement to be fed on a variable tension, thus allowing the functioning limits of the watch to be checked.

### - DELTATEST measuring apparatus

The above ensures accurate assessment of the instant rate of the watch (see Application of DELTATEST, folder 5/6-1510).

### - Key for trimmer 1510

The above is used when adjusting in the watch by means of the trimmer (fig. 2.4)

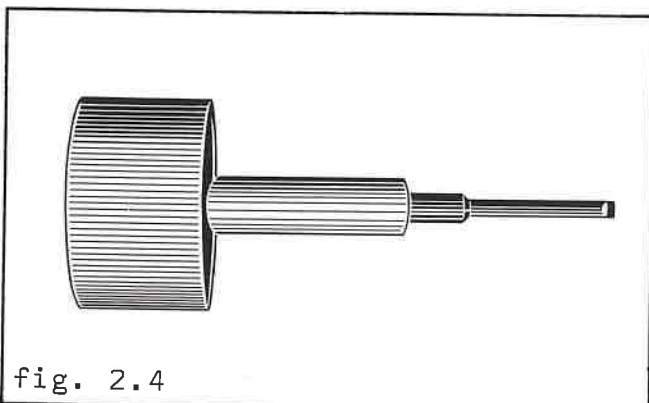

### - ALITEST checking apparatus

This allows supply of a fixed or variable feed, as well as carrying out of all the necessary tests for diagnostic purposes. (see Application of ALITEST, folder 5/6-1510).

## Cleaning

### Recommendations:

It is necessary to have an efficient cleaning machine; the baths must be very clean. In the event of the latter being heated, they must not exceed 60<sup>o</sup> C.

### IMPORTANT - to be observed strictly:

The following are not to be cleaned in the machine:

- date indicator
- power cell
- motor module
- electronic module
- minute wheel

The date indicator and power cell may be dry-cleaned (brushes, selvyt).

NEVER clean the electronic module - only a light air jet may be applied (small blower used in watch trade). It is thus imperative that the electronic module be handled with great care, not touching it with the fingers, and put aside in a clean place away from any possible dust. The lower power cell bridge may be cleaned carefully by means of a buff.

## DISASSEMBLING

OP.NO.	ORDER OF OPERATIONS DISASSEMBLING	PART NO.	FIXING DEVICE	LUBRIFICATION POINT CODE	REMARKS
--------	--------------------------------------	-------------	------------------	--------------------------------	---------

### 4.1.0. CASE PARTS AND POWER CELL

4.1.1.	OPEN THE CASE				
4.1.2.	POWER CELL BRIDLE WITH SCREW FITTED	1510-9200			
4.1.3.	POWER CELL	9903			
4.1.4.	HAND-SETTING STEM	1510-9050	PRESSURE LEVER		
4.1.5.	UNCASE		2 SCREWS 2393		
4.1.6.	SET MOVEMENT ON MOVEMENT HOLDER				TIME DISPLAY UNDERNEATH
4.1.7.	REFIT HAND-SETTING STEM		PRESSURE LEVER		
4.1.8.	TURN MOVEMENT OVER				
4.1.9.	HANDS				
4.1.10.	DIAL		DIAL HOLDER		SEE 4.1.10.0
4.1.11.	DIAL RESTS	1510-1545 1510-1546			

### 4.2.0. MODULES AND WHEEL TRAIN

4.2.1.	TURN MOVEMENT OVER				
4.2.2.	MOTOR CONTACT SCREW		1 SCREW 2594		
4.2.3.	ELECTRONIC MODULE	1510-9150	3 SCREWS 2399 3 WASHERS 1510-9151		SEE 4.2.3.0
4.2.4.	POWER CELL INSULATOR	1510-9206			
4.2.5.	MOTOR MODULE	1510-9100	2 SCREWS 2397		SEE 4.2.5.0
4.2.6.	FRICTION SPRING OF CENTER SECOND WHEEL	1510-9005	1 SCREW 2102		SEE 4.2.6.0
4.2.7.	WHEEL TRAIN BRIDGE	1510-9001	2 SCREWS 2398		
4.2.8.	CENTER SECOND WHEEL	1510-9015			
4.2.9.	THIRD WHEEL	1510-9018			

OP.NO.	ORDER OF OPERATIONS DISASSEMBLING	PART NO.	FIXING DEVICE	LUBRIFICATION POINT CODE	REMARKS
--------	--------------------------------------	-------------	------------------	-----------------------------	---------

4.3.0. TIME DISPLAY

4.3.1.	TURN MOVEMENT OVER				
4.3.2.	DATE INDICATOR GUARD	1510-9003	2 SCREWS 2637		
4.3.3.	DATE INDICATOR	1510-9031			
4.3.4.	HOUR WHEEL	1510-9024			
4.3.5.	DOUBLE DATE SETTING WHEEL	1510-9027			
4.3.6.	DATE SETTING WHEEL	1510-9032			
4.3.7.	DATE DRIVING WHEEL	1510-9030			
4.3.8.	HAND-SETTING WHEEL	1510-9060			
4.3.9.	MINUTE WHEEL	1510-9039			
4.3.10.	THIRD WHEEL BRIDGE	1510-9002	1 SCREW 2106		
4.3.11.	CENTER WHEEL WITH CANNON PINION	1510-9021			
4.3.12.	HOUR CORRECTOR YOKE	1510-9057	1 SCREW 2394		
4.3.13.	PRESSURE SPRING FOR SETTING LEVER	1510-9052	1 SCREW 3402		
4.3.14.	SETTING LEVER SPRING	1510-9056	2 SCREWS 2617		
4.3.15.	YOKE SPRING	1510-9055			
4.3.16.	YOKE	1510-9054			
4.3.17.	SETTING LEVER	1510-9051			
4.3.18.	HAND-SETTING STEM	1510-9050			
4.3.19.	CLUTCH WHEEL	1510-9053			
4.3.20.	RELEASE PLATE FROM MOVEMENT HOLDER	1510-9000			

#### 4.1.10.0

Carefully remove the dial using two hand-levers applied to the edges of the movement holder at 6 h and 12 h.

**IMPORTANT:** Dials in aventurine are very breakable.

#### 4.2.3.0

Remove the 3 fixing screws of the electronic module, as well as the 3 contact washers situated under each screw head. Using tweezers, grip the electronic module between the middle screw hole and the edge of the circuit. Slightly raise the motor contact blade and remove the electronic module.

#### 4.2.5.0

Remove the 2 fixing screws of the motor module. Slide half of the movement out of the movement holder so as to release the motor module part (fig. 3.4). With tweezers, grip the motor module between the tip of the motor bridge and the fixing screw hole of the motor bridge (point 1, fig. 3.4). Taking care not to damage the second wheel, remove the motor module. Lay the motor module aside, away from any possible dust.

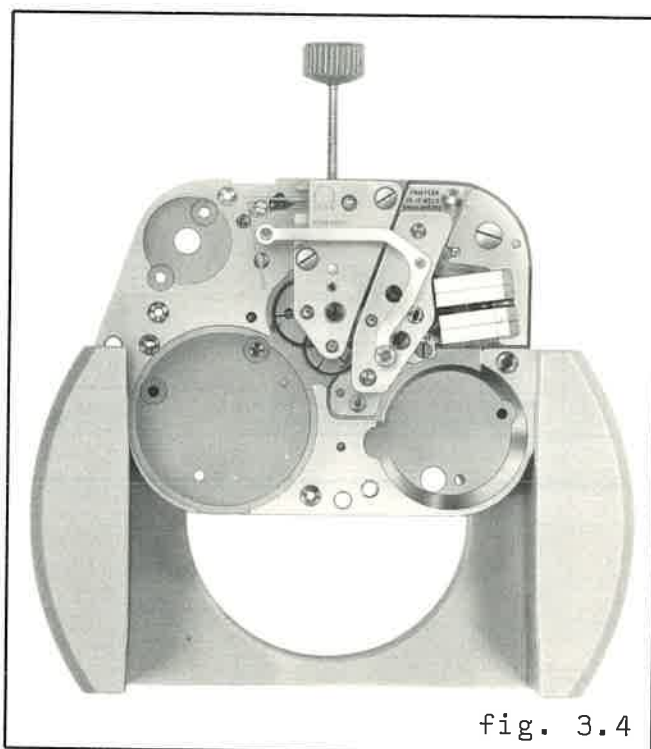

#### 4.2.6.0.

The friction spring of the center second wheel exists only on the movements nos. 34.912.000 to 34.912.659. This friction spring can be dispensed with.

## ASSEMBLING

OP. NO.	ORDER OF OPERATIONS ASSEMBLING	PART NO.	FIXING DEVICE	LUBRIFICATION POINT CODE	REMARKS
---------	-----------------------------------	-------------	------------------	-----------------------------	---------

### 4.5.0. MECHANISM

4.5.1.	INSERT PLATE IN MOVEMENT HOLDER	1510-9000			
4.5.2.	CLUTCH WHEEL AND HAND-SETTING STEM	1510-9053 1510-9050		TUBE SQUARE, PIVOT, TUBE	1.03 1.03
4.5.3.	STOP LEVER	1510-9061			
4.5.4.	TURN PLATE OVER				
4.5.5.	SETTING LEVER	1510-9051		PIVOT FUNCT.	1.03
4.5.6.	YOKE	1510-9054			
4.5.7.	YOKE SPRING	1510-9055			
4.5.8.	SETTING LEVER SPRING	1510-9056	2 SCREWS 2617	FUNCT.	1.03
4.5.9.	TEST FUNCTION OF SETTING LEVER SPRING				
4.5.10.	PRESSURE SPRING FOR SETTING LEVER	1510-9052	1 SCREW 3402		
4.5.11.	HOUR CORRECTOR YOKE	1510-9057	1 SCREW 2394	PINION	1.03 SEE 4.5.11.0.

### 4.6.0. TIME DISPLAY

4.6.1.	CENTER WHEEL WITH CANNON PINION	1510-9021		CANNON PINION	2.06
4.6.2.	THIRD WHEEL BRIDGE	1510-9002	1 SCREW 2106	JEWEL	1.03
4.6.3.	MINUTE WHEEL	1510-9039		POST	1.03
4.6.4.	CHECK FREEDOM OF DRIVING DEVICE				SEE 4.6.4.0.
4.6.5.	DATE DRIVING WHEEL	1510-9030			SEE 4.6.5.0.
4.6.6.	DATE SETTING WHEEL	1510-9032			
4.6.7.	DOUBLE DATE SETTING WHEEL	1510-9027			
4.6.8.	HOUR WHEEL	1510-9024			
4.6.9.	HAND-SETTING WHEEL	1510-9060		PIVOTG.	1.03 SEE 4.6.9.0.
4.6.10.	DATE INDICATOR	1510-9031			SEE 4.6.10.0.
4.6.11.	DATE INDICATOR GUARD	1510-9003	2 SCREWS 2637	JEWEL	1.03
4.6.12.	CHECK FUNCTIONING OF DATE				SEE 4.6.12.0.

OP.NO.	ORDER OF OPERATIONS ASSEMBLING	PART NO.	FIXING DEVICE	LUBRIFICATION		REMARKS
				POINT	CODE	

4.7.0. WHEEL TRAIN

4.7.1.	TURN MOVEMENT OVER					
4.7.2.	THIRD WHEEL	1510-9018		PIVOTG.	1.03	
4.7.3.	CENTER SECOND WHEEL	1510-9015		PIVOTG.	1.03	
4.7.4.	CHECK TENSION OF PRESSURE SPRING FOR STOP LEVER					SEE 4.7.4.0.
4.7.5.	WHEEL TRAIN BRIDGE	1510-9001	2 SCREWS 2398	2 JEWELS	1.03	
4.7.6.	CHECK ENDSHAKE AND FREE- DOM OF SECOND AND THIRD WHEELS					SEE 4.7.6.0.

4.8.0. MODULES AND CASE PARTS

4.8.1.	MOTOR MODULE	1510-9100	2 SCREWS 2397			SEE 4.8.1.0.
4.8.2.	CHECK HAND-SETTING FUNCTION					BY OPERATING HAND-SETTING STEM
4.8.3.	TURN MOVEMENT OVER					
4.8.4.	4 DIAL RESTS	1510-1545 1510-1546				
4.8.5.	DIAL		HOLDERS			SEE 4.8.5.0.
4.8.6.	HANDS					SEE 4.8.6.0.
4.8.7.	REMOVE HAND-SETTING STEM		PRESSURE LEVER			PRESS VERTICALLY ON SETTING LEVER STAFF
4.8.8.	CASE-UP		2 SCREWS 2393			
4.8.9.	HAND-SETTING STEM	1510-9050	PRESSURE LEVER			PRESS VERTICALLY ON SETTING LEVER STAFF
4.8.10.	CHECK TENSION OF STOP LEVER SPRING					SEE 4.8.10.0.
4.8.11.	POWER CELL INSULATOR	1510-9206				
4.8.12.	ELECTRONIC MODULE	1510-9150	3 SCREWS 2399 3 WASHERS 1510-9151			SEE 4.8.12.0.
4.8.13.	FIX MOTOR CONTACT BLADE			1 SCREW 2594		
4.8.14.	CHECK FUNCTIONING					SEE 4.8.14.0.
4.8.15.	POWER CELL	9903				
4.8.16.	POWER CELL BRIDLE, SCREW FITTED	1510-9200				
4.8.17.	ADJUST THE RATE					SEE FOLDER 2-1510
4.8.18.	CLOSE THE CASE					

#### 4.5.11.0

Check endshake of pinion (normal = 0.01 to 0.02 mm).

#### 4.6.4.0

Check freedom of driving device on its staff. This may be done by means of a blower.

#### 4.6.5.0

Place in position the date driving wheel.

Note: At each revolution, the driving finger (2, fig. 4.4) of the date driving wheel must enter into contact with a long pin (3) of the driving device (1).

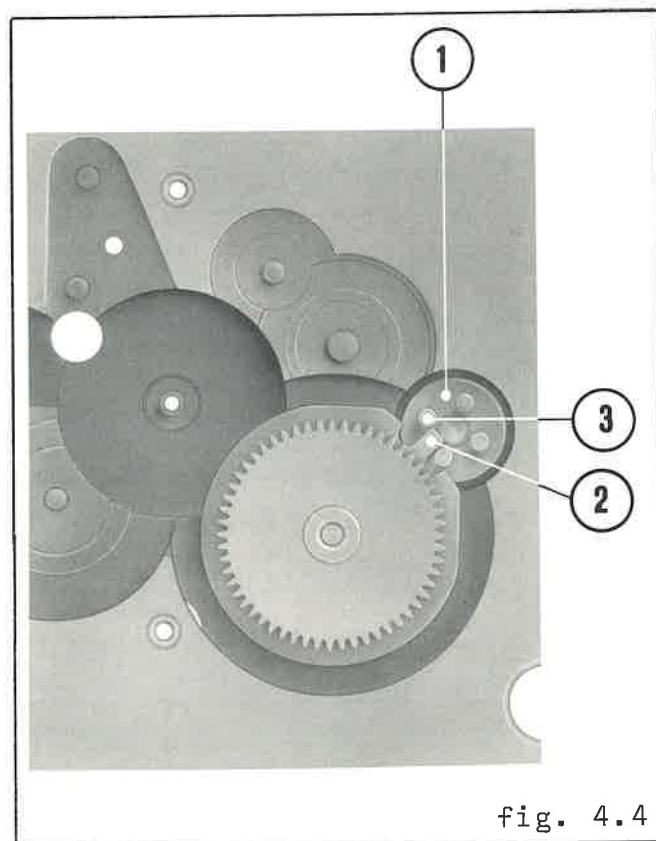

#### 4.6.9.0

After having oiled the jewel, place in position the hand-setting wheel with the short side of its staff on the plate side.

#### Note:

If the hand-setting wheel, date indicator guard or plate have been changed, check endshake of hand-setting wheel (normal: 0.02 - 0.03 mm).

#### 4.6.10.0

Place in position the date indicator.

**IMPORTANT:** A tooth of the date indicator must be inserted between the 2 long pins of the driving device.

**Note:** If the date indicator is changed, check, before placing it in position, its freedom in the respective seating of the date indicator guard by making it turn with the aid of a blower.

#### 4.6.12.0

Check functioning of the date indicator by putting the hand-setting stem in position 2 (correction of the hour) and turning the crown.

#### 4.7.4.0

Check tension of the pressure spring for stop lever. The top of the pressure spring must be 0.55 mm above the stop lever (fig. 5.4).

#### 4.7.6.0

The friction spring of the center second wheel exists only on the movements nos. 34.912.000 to 34.912.659. This friction spring can be dispensed with.

#### 4.8.1.0

Position the motor module in such a manner that the pinion of the motor wheel engages with the second wheel. Fix motor module on plate by means of its 2 screws.

#### 4.8.5.0

Fit the dial, pressing it very carefully with skin buffs opposite the dial feet, i.e. at 6 h and 12 h.

**IMPORTANT:** Dials in aventurine are very breakable.

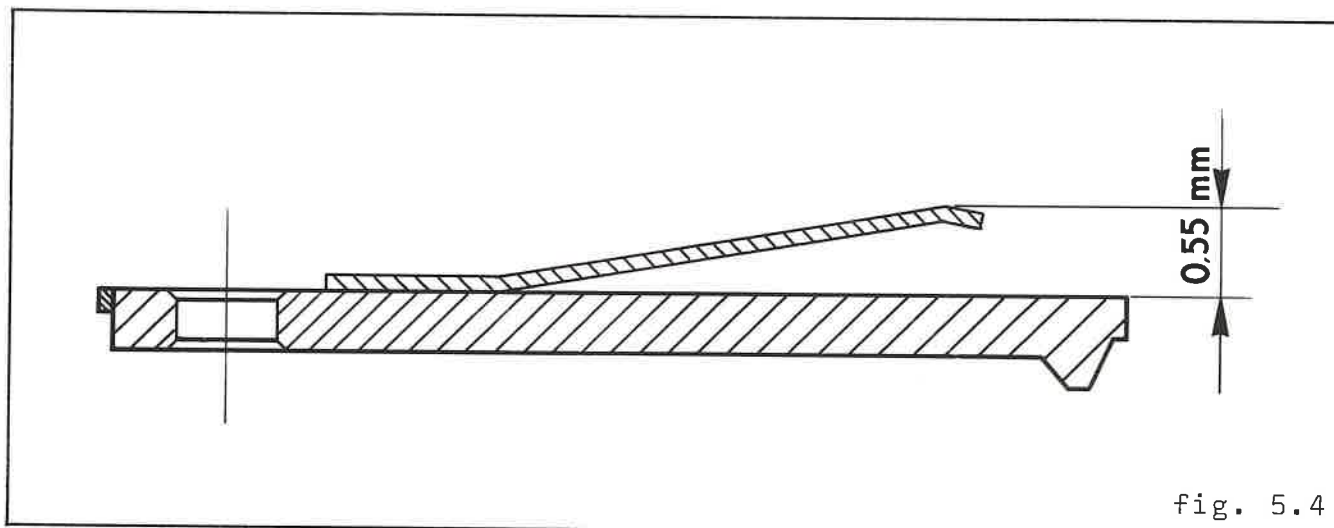

fig. 5.4

#### 4.8.6.0

Place hand-setting stem in position "2" (correction of the hour). Set the date disc between two dates and fit the hour hand at 12 h. Fit minute hand likewise at 12 h. Check that the date change occurs when the hands are at midnight. Fit the second hand taking care to ensure that it is correctly positioned over a stroke of the dial minute-track.

**IMPORTANT:** Never push the second hand forward or backward, as this could damage the pallets of the motor module.

#### 4.8.10.0

Place the hand-setting stem in position 1 (neutral). Check tension of the stop lever spring. The stop lever spring must be tangential to the interior of the hole situated underneath the tip of this spring (1 fig. 6.4).

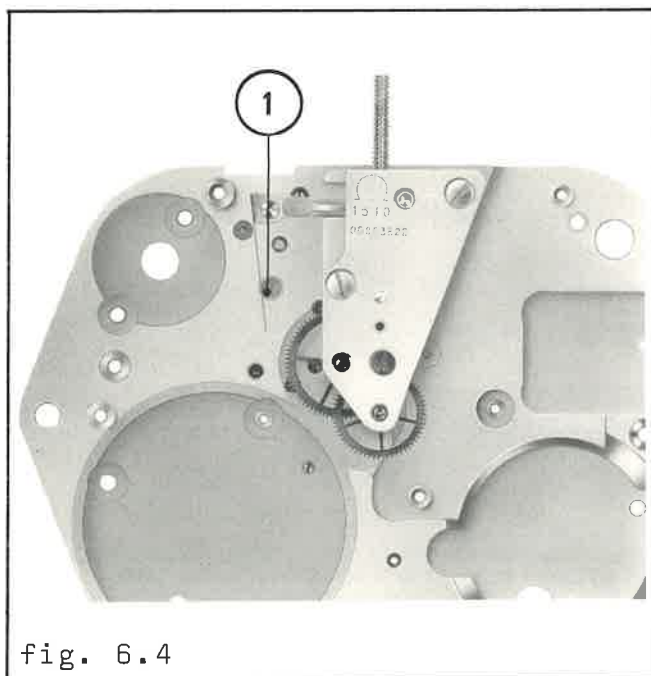

fig. 6.4

#### 4.8.12.0

Using tweezers, grip the electronic module between the hole of the module fixing-screw and the edge of the circuit (1 fig. 7.4).

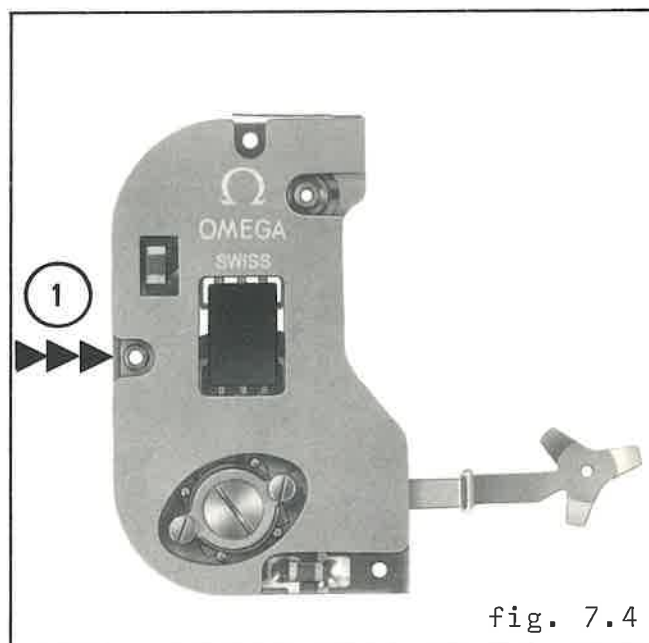

fig. 7.4

#### 4.8.14.0

1. Feed watch by means of substitute power cell. Fix the latter using the power cell bridle No. 1510-9200.
2. Measure and record the total consumption of the movement, tension 1.35 V (See Application of Alitest, folders 5/6-1510). Consumption must not exceed 14  $\mu$ A.

**Note:** If the consumption measured during operation 4.8.14.2 exceeds the limits, refer to Diagnostic.

3. Remove substitute power cell.





# Technical guide

Folder

**5-6 1510**

## Application of Deltatest and Alitest

### Note

- The figures between parentheses ( ) refer to the figures appearing in the directions for use of Deltatest and Alitest.
- The indications given refer to Deltatest ODT 3 and Alitest OAT 2.
- Indications between brackets [ ] refer to Deltatest ODT 1 and Alitest OAT 1.
- All apparatus where model is not indicated on the rear plate correspond to ODT1 and OAT1.

### 5.1 Measuring of the rate

- Press button (2) of keyboard " < 15 Hz" ["1 Hz"].
- Displace the watch in order to secure the maximum signal.
- Adjust amplification (6) whilst observing the level control given by the hand of the voltmeter. Optimal adjustment is attained when the hand is at the begin-

ning of the black zone [green zone].

- Select by means of (3) the measuring time 12 [10] seconds.
- Select by means of (4) the measuring accuracy .99 [1/100th].

### 6.1 Measuring of the power cell tension

- With the power cell placed on the table, connect the black probe to the top of the power cell (-) and the red probe to its case (+).
- The value of the tension must be around 1.35 V; if it is lower than 1.25 V, the power cell must be replaced.

## 6.2 Measuring of the current

- This measuring is effected by using the substitute power cell feed (fig. 1.5-6)



- Press button (2) 1.35 V corresponding with the feed tension of the watch.
- Unscrew and remove the motor contact screw No. 2594. Place an insulating sheet (plastic, for example, insulation of power cell) between the motor contact blade and the cover of the electronic module.
- The value measured must not exceed  $7\mu\text{A}$ .
- Remove the insulating sheet and tighten the motor contact screw.
- The new value shown is the total consumption of the watch. The latter must not exceed  $14\mu\text{A}$ . The difference between the two values represents the consumption of the motor module. It must not exceed  $7\mu\text{A}$ .

$$14\mu\text{A} - 7\mu\text{A} = 7\mu\text{A}$$

## 6.3 Analysis of motor - measuring of coil resistance

### Note

It is necessary to remove the power cell before measuring of the resistance is effected.

- Measure R between the stud of the motor blade (red probe) and the screw for fixing motor on plate (black probe), fig. 2.5-6
- The resistance of the motor should be between 1 and  $1.2\text{ k}\Omega$ . If this is not the case, the motor module must be changed.

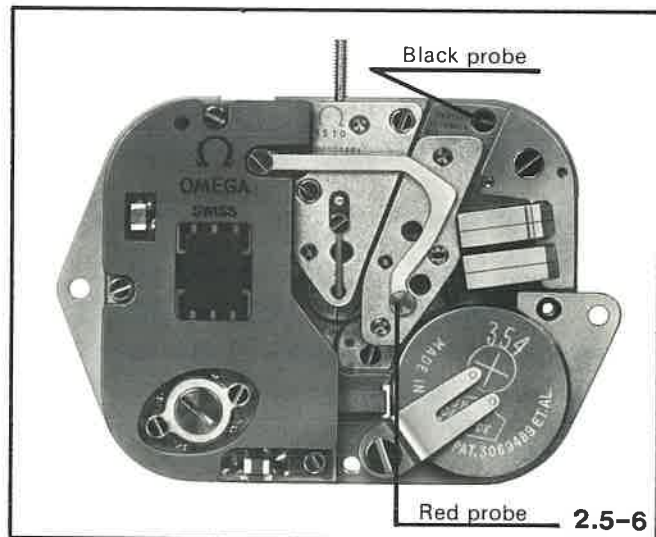

## 6.4 Measuring of the rate on Deltatest with power feed from Alitest

- Connect Alitest to INPUT of Deltatest by means of the special cable (18).
- Proceed in identical manner to "2.5-6: Measuring of the current".
- Press button "Atten Deltatest" (12) [Switch on back of Alitest in position 1].

**DIAGNOSTIC**

LEGEND : ▷ INVESTIGATE FURTHER  
 ▶ FAULT DETECTED  
 ● CORRECTION

**DISASSEMBLING OPERATIONS**

**ASSEMBLING OPERATIONS**

FROM	TO
------	----

FROM	TO
------	----

COMPLETE STOPPAGE

REMOVE AND CHECK POWER CELL;  
 SEE FOLDER 5 - 6,  
 OPERATIONS 4.1.1. TO 4.1.3.

▷ IN BAD CONDITION

▷ IN GOOD CONDITION

▶ POWER CELL WORN OUT	--	--	● REPLACE POWER CELL: SEE FOLDER 1	4.8.15.	4.8.18.
▶ POWER CELL CONTACTS OXIDIZED	--	--	● CLEAN	4.8.15.	4.8.18.
▶ ADD-SECONDS PUSHER LOCKED	4.1.1.	4.1.5.	● REPAIR OR REPLACE CASE	4.8.8, 4.8.15.	4.8.9, 4.8.18.
▶ ELECTRONIC MODULE FAULTY	--	--	● REPLACE MODULE: SEE FOLDER 3	--	--
▶ MOTOR MODULE FAULTY	--	--	● REPLACE MODULE: SEE FOLDER 3	--	--

RATE VARIATION

MEASURE RATE ;  
 SEE FOLDER 5 - 6

▷ OUTSIDE LIMITS OF ADJUSTMENT BY TRIMMER

▷ INSTANT RATE GOOD BUT VARIATIONS DURING WEAR

▶ ELECTRONIC MODULE FAULTY	--	--	● REPLACE MODULE: SEE FOLDER 3	--	--
▶ MOTOR MODULE FAULTY	--	--	● REPLACE MODULE SEE FOLDER 3	--	--
▶ TIME DISPLAY MODULE FAULTY	4.1.1.	4.2.9.	● REPLACE FAULTY PARTS	4.7.2.	4.8.18.

INTERMITTENT STOPPAGE

▷ OPEN CASE, OP. 4.1.1.

▶ POWER CELL CONTACTS OXIDIZED	4.1.2.	4.1.3.	● CLEAN	4.8.15	4.8.18.
▶ TIME DISPLAY MODULE FAULTY	4.1.2.	4.2.9.	● REPLACE FAULTY PARTS	4.7.2.	4.8.18.
▶ MOTOR MODULE FAULTY	--	--	● REPLACE MODULE ; SEE FOLDER 3	--	--
▶ ELECTRONIC MODULE FAULTY	--	--	● REPLACE MODULE ; SEE FOLDER 3	--	--

FAULTY WORKING OF THE DATE

▷ UNCASE AND CHECK DATE MECHANISM

▶ UNCASE AND CHECK DATE MECHANISM	4.1.1, 4.3.1.	4.2.5, 4.3.9.	● CORRECT OR REPLACE FAULTY PART	4.6.3, 4.8.1.	4.7.1, 4.8.18.
-----------------------------------	------------------	------------------	----------------------------------	------------------	-------------------

HOUR HAND LOCKED

▷ MINUTE WHEEL FAULTY

▶ MINUTE WHEEL FAULTY	4.1.1, 4.3.1.	4.2.5, 4.3.9.	● CORRECT OR REPLACE FAULTY PART	4.6.3, 4.8.1.	4.7.1, 4.8.18.
-----------------------	------------------	------------------	----------------------------------	------------------	-------------------

FAULTY WORKING OF STOP-SECOND

▷ DATE MECHANISM FAULTY

▶ DATE MECHANISM FAULTY	4.1.1, 4.3.1.	4.2.5, 4.3.9.	● CORRECT OR REPLACE FAULTY PART	4.6.3, 4.8.1.	4.7.1, 4.8.18.
-------------------------	------------------	------------------	----------------------------------	------------------	-------------------

▷ CONTACTS OXIDIZED

▶ CONTACTS OXIDIZED	4.1.1.	4.2.3.	● CLEAN PRESSURE SPRING OF STOP LEVER AND RESET PIN OF ELECTRONIC MODULE	4.8.12.	4.8.18.
---------------------	--------	--------	--	---------	---------