

CALIBRE

1342

25.60 Q SCS CAL CORH CORM CORS 7 or 13 jewels

Description and performances

Electronic watch with analogical display and comprising a 32 kHz high performance quartz developed and manufactured by SSIH. This ensures its great reliability and a precision at 5 seconds per month during wear. (Adjusted to this rate if necessary).

The watch in question indicates the hour, minute, second and the date.

Correction of the second and minute is effected in a very simple manner thanks to an electronic handsetting system controlled by a pusher lodged in the crown.

In drawn position, the crown allows correction of the hour (time zone) and date to be affected without disturbing the function of the watch.

The entirely modular conception of the movement ensures maximum facility in its maintenance.

1. PRINCIPLE

The quartz resonator (1) is maintained at its selfsame frequency of 32'768 Hz by an oscillator circuit (2).

The frequency is adjusted approximately by a fixed condenser (3).

On a parallel with the latter, a trimmer (4) enables fine adjustments to be made within a restricted limit of ± 1.2 seconds per day. This device provides the oscillator with maximum stability and allows particularly accurate adjustment.

Quartz oscillations are conveyed to the binary divider (5) which releases a signal of 1 Hz frequency. This signal is formed and amplified by a control level (6) which sends alternating polarity impulses to the motor Co. (7). The magnetic field induced by these impulses causes the rotor to advance at the rate of one step per second.

Motion of the motor is conveyed to the wheel-train (8) and display (9) through the medium of a pinion driven into the rotor staff (10).

The battery (11) supplies the necessary energy to the integrated circuit which feeds the quartz and the motor.

The push-button (12) lodged in the center of the crown, controls a logical circuit (13) which sends to the motor the necessary data for correction of the second (gain or loss). It also enables the motor to be set to fast working rate for correction of the minute hand.

The crown (14) has a resting position without function. When drawn, it allows corrections of the hour hand and the date.

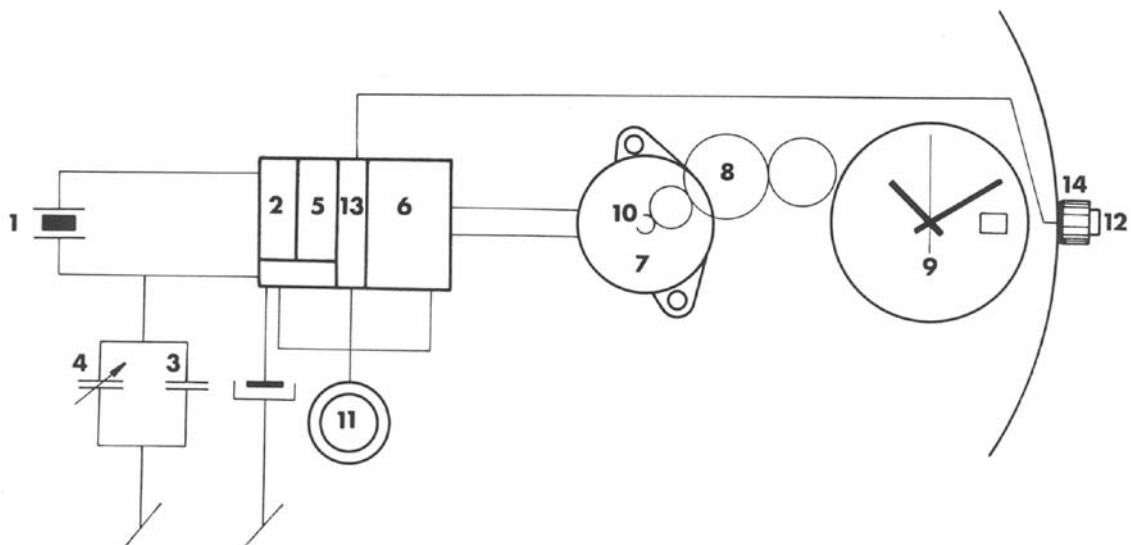

2. DESCRIPTION OF MOVEMENT

The movement consists of three modules :

- a) The electronic module with its quartz forms the time basis.
- b) The motor module which converts electric time data into rotary mechanical motion.
- c) The display module which combines the indicating and correcting organs.

The oscillator circuit CO maintains vibration of the quartz at 32,768 Hz.

The frequency dividing circuit CO, formed by 15 binary levers (dividers by 2), converts the oscillator signal into impulses of 1 Hz. A connection on the 10th dividing level enables the required frequency of 32 Hz to be obtained when handsetting is being effected.

The control level CM feeds the motor by alternating impulses of suitable amplitude and duration. The rate selector CS is controlled by the crown pusher PC. This one pusher serves for 3 functions :

A) ELECTRONIC MODULE

The electronic components

quartz Q

fixed condenser C

trimmer T

monolithic integrated circuit CI

tantalum electrolytic condenser CT

are fixed on a printed circuit and together form the electronic module.

Connection with the motor is ensured by 2 contact springs. The battery feeds the module through the negative contact blade, return of the current being obtained by means of the gilt screws.

The integrated circuit groups together about 400 transistors on a surface of 5 mm². It fills several functions which are shown in the following block-plan (Figure 4.)

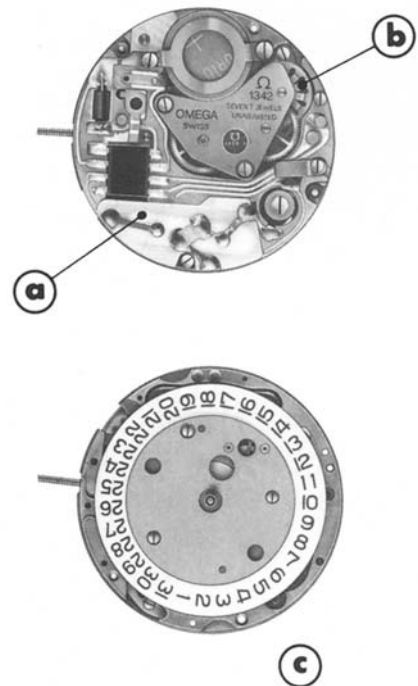

a) One brief push adds an extra impulse between 2 normal impulses, and the watch gains one second.

b) A prolonged push stops the impulse train. The motor is stopped as long as the pusher is pressed.

c) To switch the motor to fast rate at 32 Hz, the following operations must be carried out: press the pusher for 5 seconds, release briefly; press again. The motor turns at fast rate for as long as the pressure is maintained, and then reverts to normal rate.

The electronic switch CC enables the tension on the oscillator circuit and the dividing circuit to be stabilized by means of the tantalum electrolytic condenser.

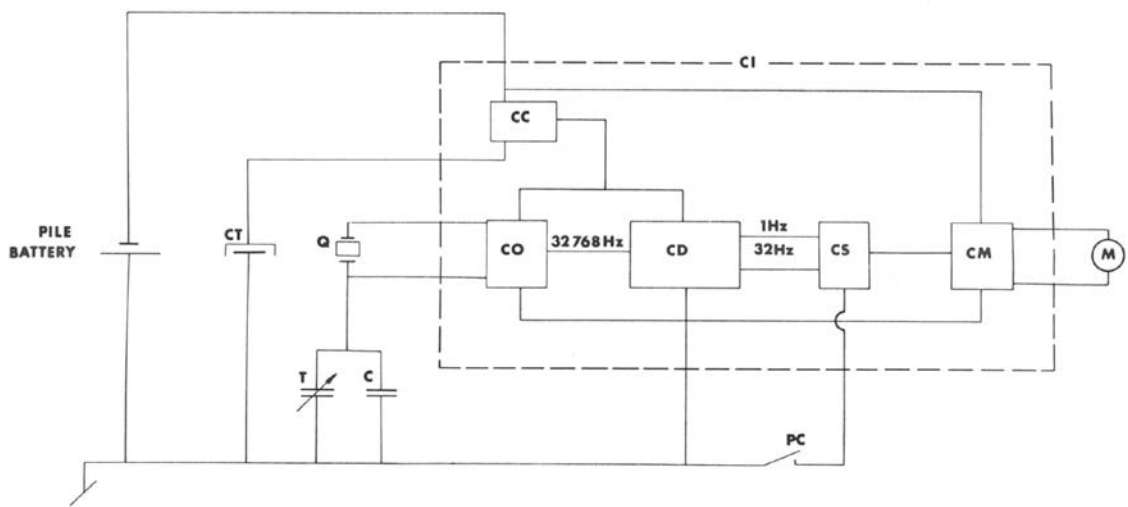

B) MOTOR MODULE

This motor is of the electromagnetic, rotary, step-by-step type. In normal function,- it receives every second a driving impulse of 8 milliseconds duration. These impulses are alternating (fig. 5).

When handsetting is effected, the motor receives 32 impulses par second, and consequently turns 32 times faster than at the normal rate.

The motor is chiefly composed of the following elements :

magnetic circuit	1, 2, 3, 4
rotor	5
coil	6
lid of motor	7

The motor functions in the following manner : (fig. 6 & 7).

When a current goes through the coil (6), a difference in magnetic potential occurs between the parts (1) and (4) of the magnetic circuit, producing a magnetic field around the air gaps (8). This field in its turn exerts some forces on the teeth of the rotor (5), resulting in a torsion couple.

Between 2 electric impulses, the motor lid (7) determines the stable balance positions of the rotor.

The motor coil is connected to the electronic module through the medium of a printed circuit (9).

The motion of the rotor is transmitted to the wheel-train through the pinion (10).

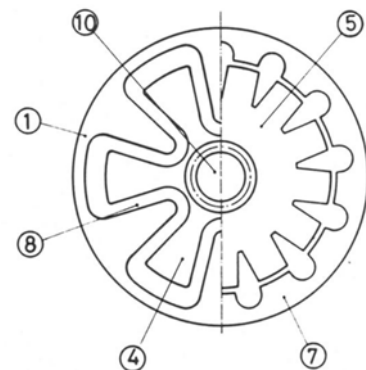
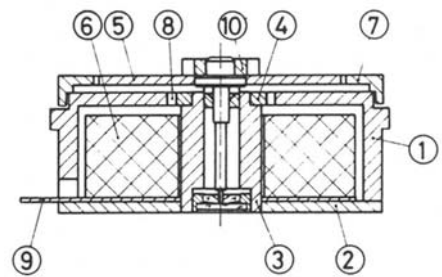
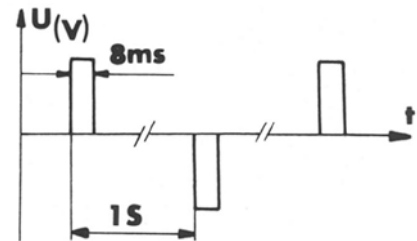

C) DISPLAY MODULE

This module comprises on the movement side

the battery

the reduction wheel and second wheel

on the dial side

the reduction wheel-train

the handsetting and date correction mechanisms.

Wheel-train

The motor Pinion (1) drives, through the reduction wheel (2), the second wheel (3), the third wheel (4), the center wheel (5), the double minute wheel (6 and 7) and the hour wheel (8).

Date

The hour wheel has a double finger (9) which actuates the Maltese cross of the intermediate date wheel (10). The latter also possesses a finger which, in its turn, drives a second Maltese cross forming part of the date driver (11). The 4 studs of the latter mesh with the teeth of the indicator (12).

Hour corrector

The minute wheel consists of 2 superposed parts (6 and 7), magnetically coupled by the magnets (13). When the handsetting stem is in resting position, the wheel operates as one piece only. With the handsetting stem in drawn position, the clutch wheel (14) and double setting wheel (15) drive the hour wheel (8) as well as the minute wheel plate (7) without losing the exact indication of the second and the minute, the magnetic couple of the minute wheel being weaker than the motor couple.

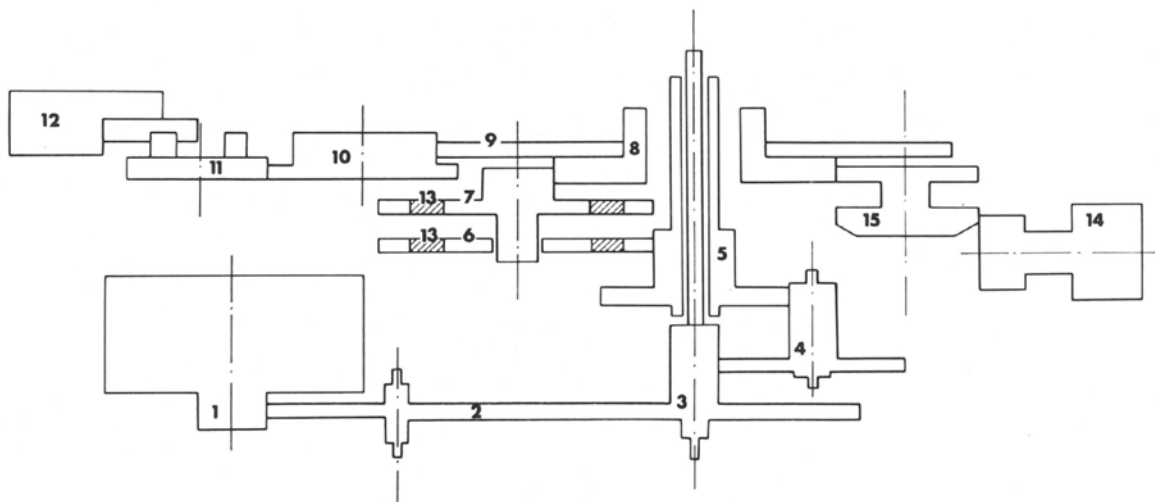

3. FUNCTIONING OF THE CORRECTING DEVICES

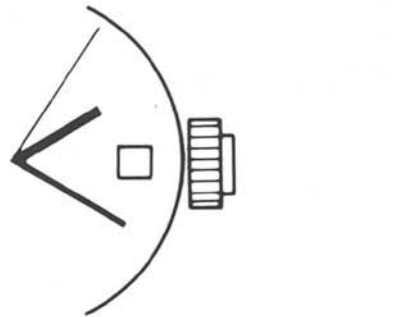

Stem in position 1
no function

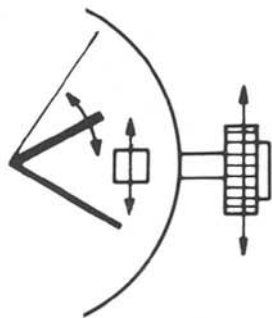

Stem in position 2
correction of the hour (time zone) and date

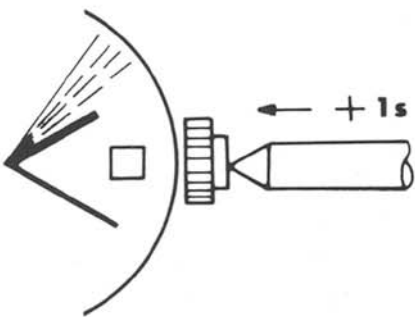

Brief pushes on the button
the second advances at the rate of one stop with each push.

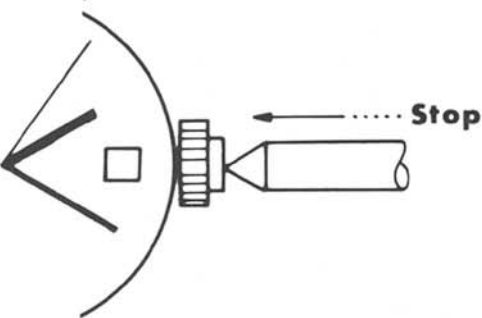

Continued pressure on pusher
the second stops

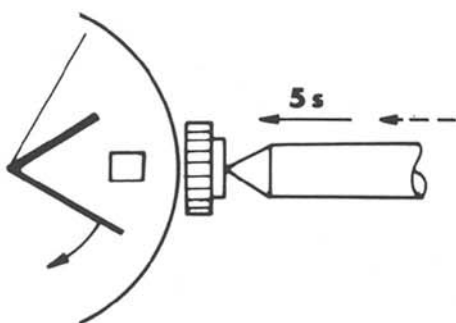

5 seconds' pressure on pusher
release briefly
press again

rapid advance of minute hand
(1 dial revolution in 2 minutes)

3. TECHNICAL DATA AND PERFORMANCE OF CALIBRE 1342

Dimensions :	Diameter : 25.58 mm Height of movement 4.00 mm Height on battery 4.20 mm
Frequency of resonator :	32.768 Hz = 2^{15}
Quality factor :	Typical = 100,000
Thermic coefficient :	0.1 s/d for a variation of $\pm 5^{\circ}$ C
Consumption :	Maximum 5 μ A
Running time with 60 mAh battery :	About 15 months
Variation during wear :	Better than ± 5 seconds/month
Shock resistance :	Shocks conforming to NIHS norms: residual effect rectifiable through adjustment system
Resistance to magnetic fields :	NIHS magnetism test no effect
Temperature functioning limits :	From 0 to 60° C

CALIBRE

1342

25.60 Q SCS CAL CORH CORM CORS 7 or 13 jewels Checking and maintenance

DIAGNOSIS

	Operations to be followed
Disassembling	1.0 to 7.5
Assembling	8.0 to 15.4
Changing of battery	1.1 + 2.1 + 2.2 + 13.1 + 13.2 + 15. 1 + 15.4
Rate adjustment	15. 1 to 15.4
Exchange of motor module	1.1 + 2.1 + 2.2 + 3.1 + 4.1 + 4.3 + 4.4 + 11.1 + 11.2 + 11.4 + 12.2 to 12.4 + 13.1 + 13.2 + 15.4
Exchange of electronic module	1.1 + 2.1 + 2.2 + 3.1 + 12.2 to 12.4 + 13.1 + 13.2 + 15.1 to 15.4
Exchange of movement	
a) Remove former movement	1.1 to 1.5
b) Preparation for new movement	1.2
c) Fitting of new movement	14.1 + 14.2 + 14.4 + 14.5 + 15.1 to 15.4

ORDER OF OPERATIONS	PART NO.	FIXING DEVICE	REMARKS
---------------------	----------	---------------	---------

DISASSEMBLING

1.0 EXTERIOR

1.1 Open the case			
1.2 Handsetting stem	1342.9100		Press head of setting lever axle (red)
1.3 Uncase		2 screws 2297 2 clamps	
1.4 Hands			
1.5 Dial			

2.0 BATTERY

2.1 Fixing clamp for battery	1342.9033	2 screws 2396	
2.2 Battery	9910		

3.0 ELECTRONIC MODULE

3.1 Electronic module	1342.9600	3 screws 2697	Do not dismantle or wash electronic module
3.2 Head of setting lever axle	1342.9104		
3.3 Clutch wheel	1342.9101		

ORDER OF OPERATIONS	PART NO.	FIXING DEVICE	REMARKS
---------------------	----------	---------------	---------

4.0 MOTOR

4.1	Wheel-train bridge	1342.9005	2 screws 2484	
4.2	Second wheel	1342.9242		
4.3	Reduction wheel	1342.9211		
4.4	Motor	1342.9400	2 screws 2484	Do not dismantle or wash motor module

5.0 CALENDAR

5.1	Date indicator guard	1342.9020	3 screws 2699	
5.2	Date indicator	1342.9235		
5.3	Date driver	1342.9232		
5.4	Intermediate date wheel	1342.9229		
5.5	Hour wheel	1342.9244		

6.0 MECHANISM II

6.1	Center wheel bridge	1342.9008	2 screws 2699	
6.2	Setting wheel	1342.9217		Fitted into center wheel bridge
6.3	Minute wheel	1342.9221		See 6.3.0
6.4	Center wheel	1342.9240		
6.5	Third wheel	1342.9208		

7.0 MECHANISM I

7.1	Return spring for setting lever	1342.9109	1 screw 2699	
-----	------------------------------------	-----------	--------------	--

ORDER OF OPERATIONS	PART NO.	FIXING DEVICE	REMARKS
7.2 Setting lever jumper	1342.9105	2 screws 2699	
7.3 Setting lever	1342.9102		
7.4 Yoke spring	1342.9108		
7.5 Clutch wheel yoke	1342.9106		

6.3.0 Cleaning of minute wheel

Separate the 2 wheels for this operation. Cleaning of the magnetic components should not be effected in a cleaning machine but in a benzine holder of which the bath will be perfectly clean and free from any metallic particles. Check, however, the cleanliness of the magnets.

ORDER OF OPERATIONS	PART NO.	FIXING DEVICE	LUBRICATION		REMARKS
			POINT	CODE	

ASSEMBLING

8.0 MECHANISM I

8.1 Clutch wheel	1342.9101		groove	1.03	
8.2 Handsetting stem	1342.9100		square, pivot, groove	1.03	
8.3 Clutch wheel yoke	1342.9106		functions	1.03	
8.4 Yoke spring	1342.9108				
8.5 Setting lever	1342.9102		pivot, functions	1.03	
8.6 Setting lever jumper	1342.9105	2 screws 2699	functions	1.03	
8.7 Return spring for setting lever	1342.9109	1 screw 2699	function	1.03	

ORDER OF OPERATIONS	PART NO.	FIXING DEVICE	LUBRICATION		REMARKS
			POINT	CODE	

9.0 MECHANISM II

9.1	Third wheel	1342.9208				
9.2	Center wheel	1342.9240				
9.3	Minute wheel	1342.9221		post	1.03	
9.4	Setting wheel	1342.9217		post	1.03	Assemble simultaneously setting wheel and center wheel bridge
9.5	Center wheel bridge	1342.9008	2 screws 2699			

10.0 CALENDAR

10.1	Hour wheel	1342.9244				
10.2	Intermediate date wheel	1342.9229				
10.3	Date driver	1342.9232				
10.4	Date indicator	1342.9235				
10.5	Date indicator guard	1342.9020	3 screws 2699			

11.0 MOTOR

11.1	Motor	1342.9400	2 screws 2484			
11.2	Reduction wheel	1342.9211				
11.3	Second wheel	1342.9242				
11.4	Wheel-train bridge	1342.9005	2 screws 2484			

12.0 ELECTRONIC MODULE

12.1	Head of setting lever axle	1342.9104				
12.2	Electronic module	1342.9600	3 screws 2697			

ORDER OF OPERATIONS	PART NO.	FIXING DEVICE	LUBRICATION		REMARKS
			POINT	CODE	
12.3 Check consumption					maxi 5.5 μ A (1.35 V)
12.4 Check tension mini and maxi					1.20-1.60 V

13.0 BATTERY

13.1 Battery	9910 or Vartachron 503				If main plate to be changed, put bat- tery insulator 1342.9032
13.2 Fixing clamp for battery	1342.9033	2 screws 2396			Guide hole located elec- tronic module side

14.0 EXTERIOR

14.1 Dial					
14.2 Hands					Support wheel- train bridge with a stan- dard movement holder (11 $\frac{1}{2}$ ''')
14.3 Remove handset- ting stem	1342.9100				Press head of setting lever axle
14.4 Case up		2 screws 2297 2 clamps			
14.5 Handsetting stem	1342.9100		Crown gasket	2.15	

15.0 RATE ADJUSTMENT

15.1 Open the case, place watch without back on the captor, movement side up, and press key "15 Hz" of Deltatest 1 Hz ODT 1
Note: As a general rule, a measuring time of 12 seconds and a measuring accuracy of 1/100 second will be used.

15.2 Adjust the watch by means of the trimmer, avoiding any possible pressure during this operation. Correct the rate according to the client's indications or otherwise in the following manner (in the event of changing the module, for example):
 In premises where the temperature is between 21°C and 26°C, the rate of the watch (back closed) should be between + 0.15 s/d and + 0.25 s/d, for this purpose, the watch should be stabilized during one hour on the premises and then adjusted (back open) to approximately + 0.30 s/d. With this latter adjustment, the majority of watches will conform to the tolerance of \pm 5 seconds per month **during wear**.

15.3 Close the case and check rate on Deltatest.

15.4 Water-resistant models: check water-resistance

DIAGNOSIS
1342

LEGEND

▷ INVESTIGATE FURTHER

▶ FAULT DETECTED

●

CORRECTION (SEE OPERATION ORDER PAGE 7 CHECKING AND MAINTENANCE FOLDER)

